

ELEVADOR DE ESCOTILLAS • ELECTRIC HATCH LIFTS • PISTONE SPORTELLO

ELEVADOR DE ESCOTILLAS
ELECTRIC HATCH LIFTS
PISTONE ELETTROMECCANICO



Cilindro electromecánico para abrir y cerrar escotillas, tapas de motor, etc.
Eje de acero inox.
Puede elevar hasta 340 kg.
Alimentación 12V.

Electromechanical actuator made of non corrosive materials and completely sumersible.
Stainless steel ram.
Up to 750 lbs lift.
Operation: 12V.

Pistone elettromeccanico per aprire e chiudere le botole, coperchi motore etc.
Asse in acciaio inox.
Solleva fino a 340kg.
Alimentazione 12V



REF	RECOGIDO RETRACTED DIMENSIONI	EXTENDIDO EXTENDED ESTENSIONE	RECORRIDO STROKE CORSA
LENHL400	38 cm	48 cm	10 cm
LENHL800S	53 cm	74 cm	20 cm
LENHL800	64 cm	84 cm	20 cm
LENHL1200S	64 cm	94 cm	30 cm
LENHL1200	74 cm	104 cm	30 cm
LENHL1600S	74 cm	114 cm	40 cm
LENHL1600	84 cm	124 cm	40 cm
LENHL2000S	84 cm	134 cm	50 cm
LENHL2000	94 cm	145 cm	50 cm
LENHL2400S	94 cm	155 cm	60 cm
LENHL2400	104 cm	165 cm	60 cm
LENHL2600	120 cm	185 cm	66 cm
LENHL3000	120 cm	195 cm	76 cm



INTERRUPTOR ELEVADOR DE ESCOTILLAS
HATCHLIFTS SWITCHS
INTERRUTTORE ELEVATORE

REF
LEN10225



TAPA DE REGISTRO • INSPECTION PLATE • TAPPO DI ISPEZIONE

TAPA REGISTRO
INSPECTION PLATE
TAPPO ISPEZIONE

Termoplástico ABS antienviejamiento y resistente a los rayos ultravioleta con refuerzo robusto.

Anti-Aging, Ultraviolet-Resistant ABS Thermoplastic with robust reinforcement.

Termoplastico ABS anti-invecchiamento, resistente agli ultravioletti con robusto rinforzo.

REF	Ø INT (mm)	Ø EXT (mm)
SFRH100401	101	143
SFRH100601	151	198
SFRH100801	180	250

SEAFLO



Cierre hermético a rosca con aro tórico.
Base de plástico blanco.
Tapa transparente de ABS.
Resistente a los rayos U.V.

Screw-on inspection cover watertight with O-ring seal.
White base and clear ABS cover.

Chiusura ermetica a filetto con o-ring. Base in plastica bianca. Tappo trasparente in ABS resistente ai raggi UV.

REF	Ø INT	Ø EXT	
GS31295	102 mm	145 mm	1
GS31296	127 mm	165 mm	1
GS31297	152 mm	200 mm	1

GOLDENSHIP



Cierre hermético a rosca con aro tórico.
Fabricada en plástico resistente a los rayos U.V.
Color blanco.

Screw-on inspection cover watertight with O-ring seal.
U.V. stabilized plastic.
White.

Chiusura ermetica a filetto con o-ring.
In plastica resistente ai raggi UV. Colore bianco.

REF	Ø INT	Ø EXT	
GS31290	102 mm	145 mm	1
GS31291	127 mm	165 mm	1
GS31292	152 mm	200 mm	1

GOLDENSHIP



CUBIERTA & HERRAJES • DECK & IRONWORK • PONTE E FERRAMENTA

RECAMBIOS MARINOS

REJILLA VENTILACIÓN • LOUVER VENT • GRIGLIA VENTILAZIONE

REJILLA DE VENTILACIÓN LOUVER VENT GRIGLIA VENTILAZIONE

Sencillo y actual diseño, fabricado en plástico ABS, resistente a la corrosión. Para sistemas de ventilación de 76 mm o 102 mm.

Clean, contemporary, louver design. Made of corrosion-resistant paintable ABS plastic, for 3" or 4" ventilation system.

In plastica ABS, resistente alla corrosione. Per sistema di ventilazione da 76mm o 102mm.



REF			
GS31195		70 x 446 mm	1
GS31196		70 x 446 mm	1



Fabricado en acero inox Made of stainless steel. In acciaio inox.

REF			
GS31176		127 x 115 x 0,8 mm	1
GS31177		230 x 115 x 0,8 mm	1
GS31175		127 x 65 x 0,8 mm	1

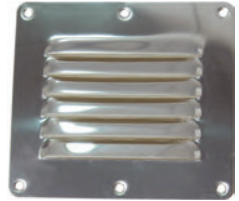

GS31176



GS31177

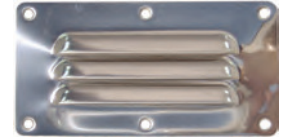

GS31175

COLECTOR VENTILACIÓN COLLECTOR BOX COLLETTORE VENTILAZIONE

Fabricado en plástico. Para usar con las rejillas GS31195-GS31196.

Made of plastic. For use with Venturi louvered vents GS31195-GS31196.

In plastica. Da usare con griglia GS31195-GS31196.

Fabricado en acero inox Made of stainless steel. In acciaio inox.

REF			
GS31180		325 x 76 x 27 mm	1

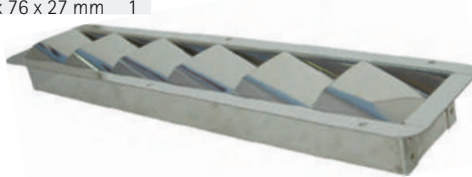

REF			
GS31197		76 mm	1
GS31198		102 mm	1



Fabricado en nylon color blanco. Made of UV. stabilized white nylon. In nylon colore bianco.

REF			
GS31192		sólo rejilla only front solo griglia	84 x 84 mm 1
GS31194		para manguera de 3" for hose 3" per tubo de 3"	84 x 84 mm 1



GS31192



GS31194

EXTRACTOR VENTILADOR SOLAR DAY/NIGHT PLUS VENT ESTRATTORE VENTILATORE SOLARE

Extractor ventilador solar. Montaje en cubiertas o escotillas. Utiliza una batería recargable con capacidad hasta 48 horas.

Solar vent. Rechargeable battery allows 24 hours continuous operation.

Estrattore ventilatore. Montaggio sotto coperta o sportello. Utilizza una batteria ricaricabile con capacità fino a 48 ore.

REF		Ø INT	
GS13025		20 m³ / hora 100 mm	Acero inox Stainless steel Acciaio inox 1
GS13026		20 m³ / hora 100 mm	Plástico blanco White plastic Plastica bianca 1
GS13027		17 m³ / hora 76 mm	Plástico blanco White plastic Plastica bianca 1

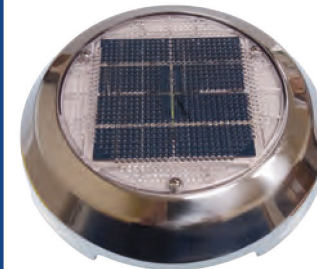

GS13025

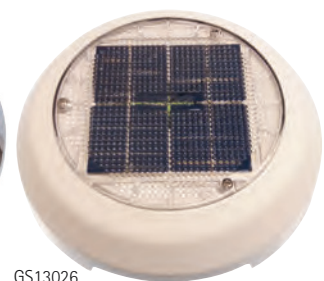

GS13026
GS13027

Fabricado en plástico color blanco. Made of white color ABS. In plastica bianco color bianco.

REF			
GS31190		257 x 125 mm	1

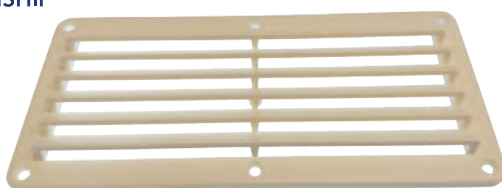

TAPA VENTILACIÓN MIDGET VENT COPERCHIO VENTILAZIONE

Fabricado en acero inox Made of stainless steel. In acciaio inox.

REF			
GS31170		45 x 40 mm	1
GS31171		55 x 63 mm	1



CUBIERTA & HERRAJES • DECK & IRONWORK • PONTE E FERRAMENTA

RECAMBIOS MARINOS

REJILLA DE VENTILACIÓN
LOUVER VENT
GRIGLIA VENTILAZIONE
 Fabricado en polipropileno. Made of polypropilene. Prodotto in polypropilene

SEAFLO

REF  

SFAV101  69,5 x 93,5 mm 1
 SFAV201 







TAPA REJILLA
VENT COVER
COPERTURA DI SFIATO

SEAFLO



Fabricado en polipropileno estabilizado UV. Muy fácil de instalar. Las dos hojas que se pueden separar para cambiar el flujo de aire. Made of UV stabilized polypropilene. Very easy to install. The two blades that can be separated to change the air flow. Prodotto in polypropilene resistente ai raggi UV. Molto facile da installare. Le due lame si possono aprire per cambiare il flusso d'aria.



2 HOJAS
 2 BLADES
 2 LAME



REF  

SFVC101  134,5 x 71,5 mm 1
 SFVC201 

2 HOJAS
 2 BLADES
 2 LAME

REF  

SFVC101  134,5 x 71,5 mm 1
 SFVC201 

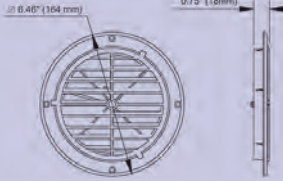
VENTILACIÓN DE FONTANERÍA
PLUMBING VENT
SFIATO IDRAULICO

SEAFLO

Fabricado en polipropileno. Se incluye una tapa superior, que se puede bloquear o quitar con la necesidad de herramientas. Made of polypropilene. A top cap is included, which can be locked on or removed with a twist of the wrist without the need of tools. Prodotto in polypropilene. Un cappuccio superiore è incluso, che può essere bloccato o rimosso con una torsione del polso senza la necessità di strumenti.

REF  

SFPV101  134,5 x 71,5 mm 1
 SFPV201 







TOMA DE CUBIERTA • DECK FILL PLATE • IMBARCHI

TOMA DE CUBIERTA
DECK PLATE
IMBARCHI

Fabricadas en polipropileno. Manufactured in polypropilene. In polypropilene

REF	TIPO	H (mm)	D (mm)	d (mm)	d1 (mm)	d3 (mm)	di (mm)
SFCW201	Water	70	85	50	40	38	34
SFCF201	Fuel	70	85	50	40	38	34

SEAFLO

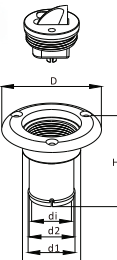
Fabricadas en fundición de acero inox AISI 316. Manufactured in precision casted stainless steel AISI-316. In acciaio inox AISI 316

REF	TIPO	H (mm)	D (mm)	d (mm)	d1 (mm)	d3 (mm)	di (mm)
GS3110	WASTE	38	38	38	38	38	38
GS3111	GAS	38	38	38	38	38	38
GS3112	DIESEL	38	38	38	38	38	38
GS3113	WATER	38	38	38	38	38	38
GS3115	GAS	50	50	50	50	50	50
GS3116	FUEL	50	50	50	50	50	50
GS3117	WATER	50	50	50	50	50	50

GOLDENSHIP



Fabricadas en bronce cromado. Made in chrome plated bronze. In bronzo cromato

REF	TIPO	H (mm)	D (mm)	d (mm)	d1 (mm)	d3 (mm)	di (mm)
GS31100	FUEL	38	38	38	38	38	38
GS31101	WATER	38	38	38	38	38	38
GS31102	FUEL	50	50	50	50	50	50
GS31103	WATER	50	50	50	50	50	50
GS31107	WASTE	38	38	38	38	38	38

GOLDENSHIP





Fabricada en plástico reforzado y aleación de cinc.

Chrome plated zinc alloy body and black plastic flange.

In plastica rinforzata e alloggiamento in zinco.

REF	Ø EXT		
GS31136	80 mm	38 mm GAS	1

PERKO®

REF	
GS31137	1



Fabricadas en bronce cromado. Tapón con llave y cadena de seguridad.

Made in chrome plated bronze. With splash-proof lock.

In ottone cromato. Cap con il tasto e la sicurezza della catena.

REF		
GS31104	38 mm WASTE	1
GS31108	50 mm DIESEL	1
GS31109	38 mm WATER	1

GOLDENSHIP



Fabricadas en bronce cromado. Tapón con llave.

Made in chrome plated bronze. With splash-proof lock.

In bronzo cromato. Tappo con chiave.

REF		
GS31105	38 mm FUEL	1
GS31106	50 mm FUEL	1

GOLDENSHIP



Con ventilación de tanque incorporada y rejilla antichispa. Tapa de cierre rápido. Fabricada en plástico reforzado.

Combination fill and tank vent with flame arrestor. Tough molded plastic flip top cap.

Con ventilazione serbatoio incorporata e griglia parascintille. Tappo chiusura rapida. In plastica rinforzata.

REF	TOMA FUEL PRESA	VENTILACIÓN VENT VENTILAZIONE		
GS31130	<input type="checkbox"/>	38 mm 16 mm GAS	90°	1
GS31131	<input checked="" type="checkbox"/>	38 mm 16 mm GAS	90°	1
GS31132	<input type="checkbox"/>	38 mm 16 mm WATER	90°	1
GS31133	<input checked="" type="checkbox"/>	38 mm 16 mm WATER	90°	1
GS31134	<input checked="" type="checkbox"/>	38 mm 16 mm GAS	35°	1

PERKO®



Fabricadas en fibra de vidrio reforzada.

Manufactured reinforced plastic.

In fibra di vetro rinforzata.

REF			
GS31120	<input checked="" type="checkbox"/>	38 mm GAS	1
GS31121	<input checked="" type="checkbox"/>	38 mm WATER	1
GS31122	<input type="checkbox"/>	50 mm GAS	1
GS31124	<input checked="" type="checkbox"/>	50 mm GAS	1

GOLDENSHIP



Fabricadas en fibra de vidrio reforzada.

Manufactured reinforced plastic.

In fibra di vetro rinforzata.

REF		
GS31125	38 mm FUEL	1
GS31126	38 mm WATER	1
GS31127	50 mm FUEL	1
GS31128	50 mm WATER	1

GOLDENSHIP



Fabricada en plástico negro. Tapa de bronce cromado. Ventilación con rejilla anti-llama incorporada. Angulo de 35°

Combination fill and tank vent with flame arrestor. Chrome plated bronze cap with black plastic base. 35° angle

In plastica nera. Tappo in bronzo cromato. Ventilazione con griglia antifiama incorporata. Angolo di 35°

REF	Ø		
GS31140	84 mm	38 mm GAS	1
GS31153	84 mm	38 mm DIESEL	1
GS31143	84 mm	38 mm WATER	1

PERKO®



LLAVE TOMA DE CUBIERTA INOX
DECK PLATE KEY SS
CHIAVE PIASTRA INOX

REF	
GS31114	1
GS31145	1

GOLDENSHIP



LLAVE UNIVERSAL INOX
UNIVERSAL DECK PLATE KEY SS
CHIAVE UNIVERSALE INOX

REF	
GS31147	1

GOLDENSHIP



TAPA RECAMBIO
REPLACEMENT CAP
TAPPO RICAMBIO

REF	
GS31139	GAS 1
GS31154	DIESEL 1
GS31144	WATER 1



ACCESORIOS PASAMANOS • RAIL FITTINGS • ACCESSORI CORRIMANO

BASE CONICA CONE BASE BASE CONICA

Bases de cono truncado para púlpitos.
Fabricado en acero inox AISI-316.
Pulido a espejo.
Incluye tornillo inox M8.

Truncated cone bases for pulpits.
Made of stainless steel AISI-316.
Mirror polished.
With stud mounting M8.

Base conica per pulpiti. In acciaio inox AISI 316.
Pulitura a specchio.
Include vite inox M8

REF	Ø EXT				
GS72490	25 mm	45°	62 x 45 mm	75 mm	1
GS72491	25 mm	60°	45 mm	70 mm	1
GS72492	25 mm	90°	45 mm	90 mm	1
GS72493	30 mm	45°	65 x 48 mm	75 mm	1
GS72494	30 mm	60°	48 mm	70 mm	1
GS72495	30 mm	90°	48 mm	62 mm	1

GOLDENSHIP

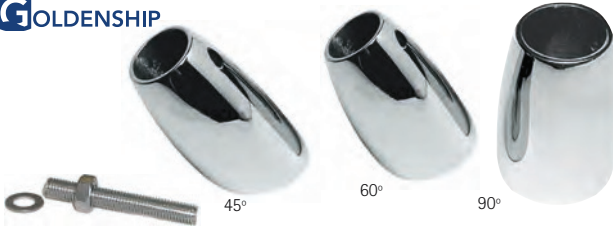

REF	Ø EXT				
GS72496	25 mm	60°	53 x 46 mm	70 mm	1
GS72497	25 mm	90°	44 mm	70 mm	1
GS72498	30 mm	60°	66 x 51 mm	80 mm	1
GS72499	30 mm	90°	51 mm	80 mm	1

GOLDENSHIP

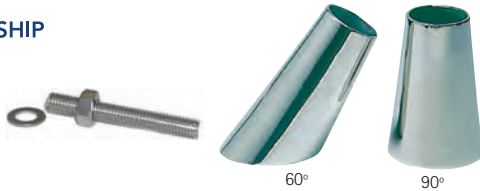

BASE REDONDA ROUND BASE BASE ROTONDA

Fabricado en acero inox AISI-316.

Made of stainless steel AISI-316.

In acciaio inox

REF	Ø EXT		Ø	
GS72335	22 mm	30°	67 mm	1
GS72336	22 mm	45°	67 mm	1
GS72337	22 mm	60°	67 mm	1
GS72338	25 mm	60°	67 mm	1
GS72339	22 mm	90°	67 mm	1
GS72340	25 mm	90°	67 mm	1

GOLDENSHIP



REF	Ø EXT		Ø	
GS72450	22 mm	45°	67 mm	1
GS72451	25 mm	45°	67 mm	1
GS72452	22 mm	60°	67 mm	1
GS72453	25 mm	60°	67 mm	1
GS72454	22 mm	90°	67 mm	1
GS72455	25 mm	90°	67 mm	1

GOLDENSHIP



BASE RECTANGULAR RECTANGULAR BASE BASE RETTANGOLARE

Fabricado en acero inox AISI-316

Made of stainless steel AISI-316.

In acciaio inox AISI 316

REF	Ø EXT			
GS72341	22 mm	60°	67 x 45 mm	1
GS72322	25 mm	60°	67 x 45 mm	1
GS72342	22 mm	90°	67 x 45 mm	1
GS72343	25 mm	90°	67 x 45 mm	1

GOLDENSHIP



REF	Ø EXT			
GS72456	22 mm	45°	67 x 45 mm	1
GS72457	25 mm	45°	67 x 45 mm	1
GS72458	22 mm	60°	67 x 45 mm	1
GS72459	25 mm	60°	67 x 45 mm	1
GS72460	22 mm	90°	67 x 45 mm	1
GS72461	25 mm	90°	67 x 45 mm	1

GOLDENSHIP

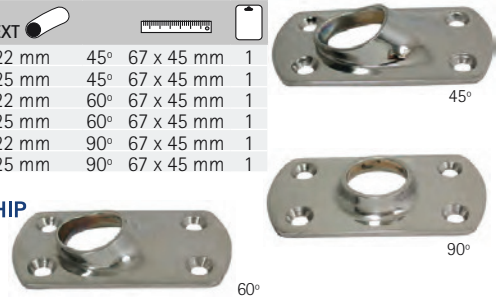

CODO 90° 90° ELBOW GOMITO 90°

Fabricado en acero inox AISI-316.

Made of stainless steel AISI-316.

In acciaio inox

REF	Ø EXT	
GS72325	22 mm	1
GS72326	25 mm	1

GOLDENSHIP



CODO 110° 110° ELBOW GOMITO 110°

Fabricado en acero inox AISI-316.

Made of stainless steel AISI-316.

In acciaio inox

REF	Ø EXT	
GS72324	22 mm	1

GOLDENSHIP



CODO TRIPLE 90° 90° THREE WAY ANGLE GOMITO TRIPLO 90°

Fabricado en acero inox AISI-316.

Made of stainless steel AISI-316.

In acciaio inox

REF	Ø EXT	
GS72462	22 mm	1
GS72463	25 mm	1

GOLDENSHIP



TERMINAL PASAMANOS INOX AISI-316
RAIL END, AISI-316 SS
TERMINALE, INOX AISI-316

REF	Ø		
GS72323	22 mm EXT	1	
GS72319	19 mm INT	1	
GS72464	22 mm EXT	1	

GOLDENSHIP

TERMINAL PERFIL INOX ASI-316
RUB RAIL END CAPS, AISI-316 SS
TERMINALE INOX AISI-316

Pulido a espejo. Se adapta a los perfiles TACO.
 Highly polished. Fits TACO rails.
 Pulitura a specchio. Si adatta a "TACO".

REF	Ref. TACO	A (mm)	B (mm)	C (mm)	
GS62180	V219679	60	47	19	1
GS62181	S11-4650P12	73	57	25	1

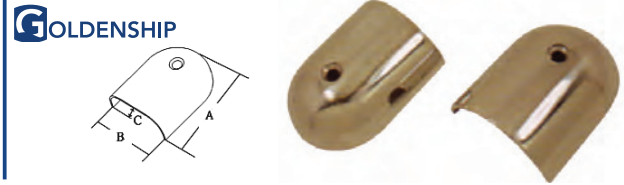

Tornillos M5. Screws M5. Viti M5.

REF	Ø (mm)		A (mm)	B (mm)	H (mm)	
GS72344	22	60° delantero forward anteriore	40	26	38	1
GS72345	25	60° delantero forward anteriore	42	29	38	1
GS72346	22	60° centro central centrale	40	26	38	1
GS72347	25	60° centro central centrale	42	29	38	1
GS72348	22	60° trasero rear posteriore	40	26	38	1
GS72349	25	60° trasero rear posteriore	42	29	38	1



UNION «T» PASAMANOS, INOX AISI-316
RAIL FITTINGS, AISI-316 SS
GIUNTO "T", INOX AISI-316

REF	Ø EXT				
GS72327	22 mm	60° universal	universal	universale	1
GS72328	25 mm	60° universal	universal	universale	1
GS72329	22 mm	60° derecha right destra			1
GS72330	25 mm	60° derecha right destra			1
GS72331	22 mm	60° izquierda left sinistra			1
GS72332	25 mm	60° izquierda left sinistra			1
GS72333	22 mm	90° universal	universal	universale	1
GS72334	25 mm	90° universal	universal	universale	1



ASAS • HANDLE • MANIGLIE

ASA HANDLE MANIGLIA

Fabricado en tubo ovalado de acero inox AISI-316. Made in oval tube stainless steel AISI-316. Tubo ovalizzato in acciaio inox AISI 316.

REF	Ø (mm)	A (mm)	B (mm)	C (mm)	
GS72290	22	305	45	39	1
GS72292	22	406	45	39	1
GS72291	22	457	51	39	1

GOLDENSHIP

Asa fabricada en PVC blando con soporte interior de plástico rígido. Puede utilizarse en el interior o exterior. Tapón para tapar los tornillos de fijación.

PVC handle with rigid core. For internal and external spaces. Hidden fastening screws.

Maniglia in PVC con supporto interno in plastica rigida. Può utilizzarsi all'interno o all'esterno. Tappini per chiudere le viti di fissaggio.

REF	Ø (mm)	
GS72066	250 x 60	1
GS72067	250 x 60	1
GS72068	250 x 60	1

GOLDENSHIP

Fabricado en tubo de acero inox AISI-316. Base de apoyo en nylon. Made in stainless steel AISI-316 and nylon base. Tubo in acciaio inox AISI 316. Base in nylon.

REF	Ø (mm)	A (mm)	B (mm)	C (mm)	
OCEMA0229	22	229	305	67	1
OCEMA02212	22	305	383	67	1
OCEMA02218	22	457	532	67	1
OCEMA02224	22	610	684	67	1

OCEANSOUTH

Fabricada en latón cromado. Manufactured in chromed brass. In ottone cromato.

REF	Ø (mm)	
GS72062	120 x 30	1

GOLDENSHIP

Fabricada en acero inox AISI-316. Manufactured in S.S. AISI-316. Tin acciaio inox AISI 316.

REF	A (mm)	B (mm)	C (mm)	
GS72064	150	32	48	1

GOLDENSHIP

GANCHO COLGADOR • HOOK • GANCIO

SOPORTE COLGADOR UTILITY HOOK GANCIO

Móvil.
Fabricado en acero inox
AISI-316.

Made of stainless steel
AISI-316 cast.
Moveable hooks.

Mobile.
In acciaio inox AISI 316

REF	(mm)	GANCHOS HOOKS GANCIO	
GS72286	63 x 38	2	1

GOLDENSHIP



GANCHO DEFENSAS FENDER HOOK GANCIO PARABORDI

Fabricado en acero inox
AISI-316.

Made of stainless steel
AISI-316 cast.

In acciaio inox AISI 316

REF	(mm)	
GS72003	21 x 30	2

GOLDENSHIP



Fijo.
Fabricado en acero inox
AISI-316.

Made of stainless steel
AISI-316 cast.
Fixed hooks.

Fisso.
In acciaio inox AISI 316

REF	(mm)	GANCHOS HOOKS GANCIO	
GS72285	70 x 45	2	1

GOLDENSHIP



Gancho con seguro
Fabricado en acero inox
AISI-316.

Snap hook made of
stainless steel AISI-316

Gancio con sicura.
In acciaio inox AISI 316

REF	(mm)	
GS72002	41 x 34	2

GOLDENSHIP



GANCHO PELICAN PELICAN HOOK GANCIO

Fabricado en acero inox
AISI-316 para cierre-
tensor de pasamanos, etc.

Made of stainless steel
AISI-316 cast.

In acciaio inox AISI 316
per chiusure, tendicinghia
etc.

REF	(mm)	(mm)	
GS72399	91	8	1

GOLDENSHIP



Plegable.
Puede montarse en
espacios pequeños y
plegarlo cuando no está
en uso.
Fabricado en acero inox
AISI-316.

Made of stainless steel
AISI-316 cast.
Folds flat when not in
use.

Piegabile.
Si può montare in spazi
piccoli e piegarlo quando
non serve.
In acciaio inox AISI 316

REF	(mm)	
GS72287	50 x 28 x 10	1

GOLDENSHIP



Gancho abierto
Fabricado en acero inox
AISI-316.

Open hook made of
stainless steel AISI-316

Gancio aperto.
In acciaio inox AISI 316

REF	(mm)	
GS72001	19 x 27	2

GOLDENSHIP



BISAGRA • HINGE • CERNIERE

BISAGRA CON TAPA COVERED HINGE CERNIERE CON TAPPO



Bisagras de acero inox 316 con tapa para cubrir los tornillos, proporcionando una limpieza de montaje muy elegante. De fácil instalación. La cubierta se monta en la bisagra mediante una cinta 3M de gran adherencia.

Made in stainless steel, AISI-316. The cover is fixed by a 3M double adhesive tape to conceal the screws. Easy installation. Expensive and up-graded look.

Cerniere in acciaio inox 316 con tappo per coprire le viti. Di facile installazione. La copertura si monta sopra la cerniera tramite un nastro 3M di grande aderenza.



PLANA FLAT PIATTA

REF	(mm)	
GS72140	37 x 36	1
GS72141	37 x 57	1
GS72144	37 x 74	1
GS72142	75 x 74	1
GS72143	65 x 65	1



GS72140

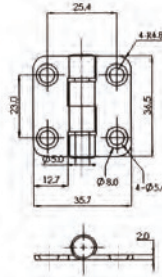

GS72142

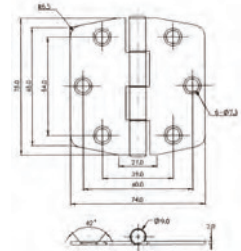

GS72141

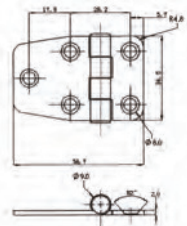

GS72143

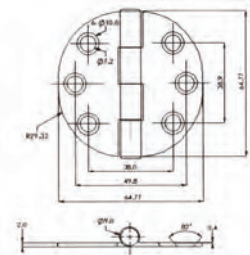

GS72144

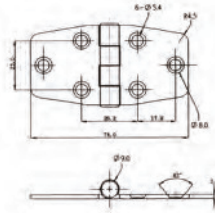

EMPOTRADA RECESSED INCASSO

REF	(mm)	
GS72145	37 x 77	1
GS72146	75 x 74	1



GS72145

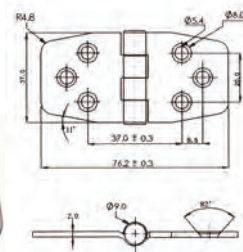

GS72146

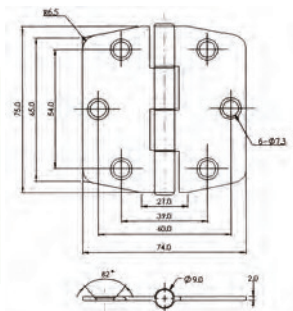

BISAGRA DESMONTABLE INOX AISI-316 TAKE-A-PART HINGE, AISI-316 SS CERNIERA SMONTABILE INOX AISI-316

Bisagra desmontable para tapas de motor, etc.

Removable hinge for motor box, etc.

Cerniera smontabile per coperchio motore etc.

Con pasador desmontable With removable pin.

Con perno rimovibile.

REF	(mm)	
GS72100	52 x 90	1
GS72101	52 x 90	1

Montaje en puerta izquierda
For mount on left side
Montaggio nella porta a sinistra.

Montaje en puerta derecha
For mount on right side
Montaggio nella porta a destra

REF	(mm)	
GS72185	39 x 72 x 2	2



Bisagra para escotillas.

Removable hinge for hatches. With cotter pin.

Cerniera removibile.

REF	(mm)	
GS72102	75 x 62	1



CUBIERTA & HERRAJES • DECK & IRONWORK • PONTE E FERRAMENTA

RECAMBIOS MARINOS

BISAGRA EMPOTRABLE
TABLE HINGE
CERNIERA AD INCASSO

Fabricada en acero inox. Made in stainless steel.
Doble pivote. 2 pins.

In acciaio inox.
Doppio perno.

REF	(mm)	
GS72170	80 x 30 x 2	2

GOLDENSHIP



BISAGRA PIANO
CONTINUOUS HINGE
CERNIERA PIATTA

Fabricada en acero inox pulido. Made of polished stainless steel.

In acciaio inox.

REF	(mm)	
GS72165	1000 x 35 x 0,8	1
GS72166	1000 x 40 x 0,8	1
GS72167	1000 x 50 x 0,8	1

GOLDENSHIP



BISAGRA. FUNDICIÓN ACERO INOXIDABLE AISI-316
HINGE. HEAVY DUTY CAST STAINLESS STEEL AISI-316
CERNIERA ACCIAIO INOX AISI 316

REF	(mm)	
GS72135	103 x 25 x 5	1
GS72131	50 x 50 x 5	1
GS72132	76 x 38 x 5	1
GS72130	72 x 38 x 5	1

GOLDENSHIP

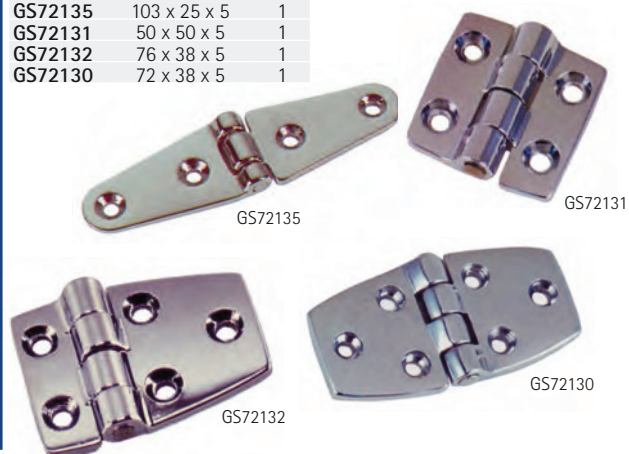

BISAGRA LATÓN ESTAMPADO CROMADO
CHROME PLATED STAMPED BRASS HINGE
CERNIERA OTTONE CROMATO

REF	(mm)	
GS72199	70 x 54 x 9	2

GOLDENSHIP



BISAGRAS CON PERNOS
HINGE WITH STUDS
CERNIERA CON PERNI

Bisagra de acero inox AISI-316, con 4 pernos roscados. Acabado pulido a espejo. Apertura: 180°
Made in stainless steel AISI-316 with 4 studs. Mirror polished. Opening: 180°

Cerniera in acciaio inox AISI-316, con quattro bulloni filettati. Levigato riflettente. Apertura: 180

REF	(mm)	
GS72172	90 x 60 x 3	1

GOLDENSHIP

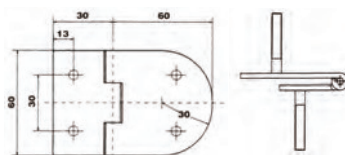

Bisagra de acero inox con 4 pernos roscados de 25 mm. Made in stainless steel with 4 studs 25mm length.

Cerniera in acciaio inox AISI-316, con quattro bulloni filettati 25 mm

REF	A (mm)	B (mm)	C (mm)	D (mm)	E (mm)	
GS72161	51	35	15	15	1,5	1
GS72162	67	48	20	23	2	1
GS72163	78	56	25	25	2	1

GOLDENSHIP

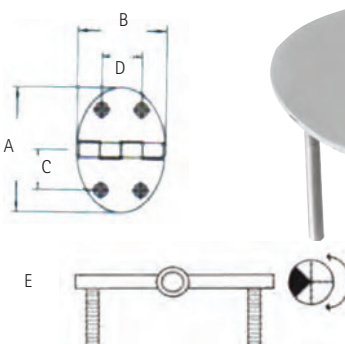

Bisagra de acero inox AISI-316, con 2 pernos roscados. Acabado pulido a espejo. Apertura: 180°
Made in stainless steel AISI-316 with 2 studs. Mirror polished. Opening: 180°

Cerniera in acciaio inox AISI-316, con 2 bulloni filettati. Levigato riflettente. Apertura: 180

REF	(mm)	
GS72171	90 x 60 x 3	1

GOLDENSHIP

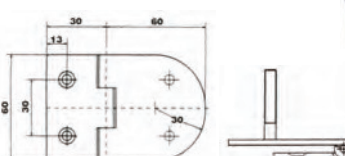

Bisagra de acero inox AISI-316, con 4 pernos roscados. Acabado pulido a espejo. Apertura: 120°
Made in stainless steel AISI-316 with 4 studs. Mirror polished. Opening: 120°

Cerniera in acciaio inox AISI-316, con quattro bulloni filettati. Levigato riflettente. Apertura: 120

REF	(mm)	
GS72173	120 x 60 x 3	1

GOLDENSHIP

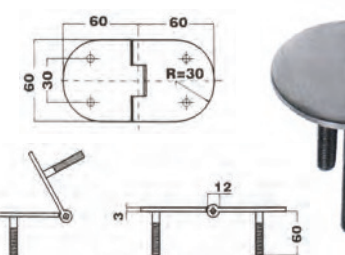

BISAGRA EN ACERO INOX
HINGE MADE OF STAINLESS STEEL
CERNIERA IN ACCIAIO INOX

GOLDENSHIP

REF	(mm)	
GS72110	39 x 39 x 2	2
GS72111	39 x 57 x 2	2
GS72112	39 x 76 x 2	2
GS72113	31 x 102 x 2	2
GS72186	38 x 76 x 2	2
GS72115	39 x 37 x 2 x 10	2
GS72116	39 x 63 x 2 x 10	2
GS72117	39 x 63 x 2 x 20	2
GS72118	40 x 130 x 2	2
GS72192	78 x 56 x 2	2
GS72193	56 x 84 x 2	2



GS72110



GS72111



GS72112



GS72113



GS72186



GS72115

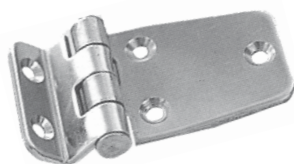

GS72116

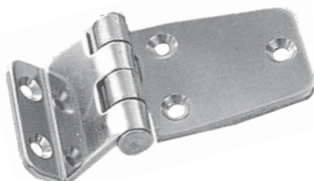

GS72117



GS72118



GS72192

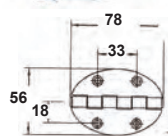

GS72193

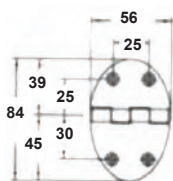

REF	A (mm)	B (mm)	C (mm)	D (mm)	E (mm)	
GS72194	51	35	15	15	1,5	2
GS72195	67	48	20	23	2	2
GS72196	78	56	25	25	2	2
GS72197	90	56	30	25	2	2

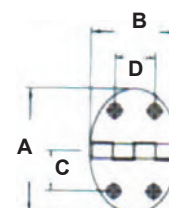

GOLDENSHIP



BISAGRA EN ACERO INOX PULIDO
HINGE MADE OF POLISHED STAINLESS STEEL
CERNIERA IN ACCIAIO INOX PULITO

REF	(mm)	
GS72184	37 x 74 x 2	1

GOLDENSHIP

Bisagra de acero inox
 Acabado pulido a espejo.
 Espesor: 2 mm
 Apertura: 270°

Stainless steel, mirror
 polished with special
 central vibration damping
 braked axis.
 Thickness: 2 mm.
 Opening: 270°

Cerniera in acciaio inox
 Levigato riflettente.
 Spessore: 2 mm
 Apertura: 270°

REF	APERTURA OPENING APERTURA	
GS72180	Standard	1
GS72181	Reversa Reverso	1

GOLDENSHIP

REF	(mm)	
GS72150	40 x 30 x 1,5	2
GS72151	40 x 40 x 1,5	2

GOLDENSHIP

REF	(mm)	
GS72152	60 x 40 x 1,5	2
GS72153	60 x 50 x 1,5	2
GS72154	60 x 60 x 1,5	1
GS72155	80 x 50 x 1,5	1
GS72156	80 x 60 x 1,5	1
GS72157	80 x 70 x 1,5	1

GOLDENSHIP

REF	(mm)	
GS72158	100 x 60 x 2	1
GS72159	100 x 80 x 2	1
GS72160	100 x 100 x 2	1

GOLDENSHIP

REF	(mm)	
GS72174	30 x 25 x 0,8	2
GS72175	30 x 30 x 0,8	2
GS72176	40 x 35 x 0,8	2
GS72177	40 x 40 x 0,8	2

GOLDENSHIP

REF	(mm)	
GS72178	50 x 40 x 0,8	2
GS72179	50 x 50 x 0,8	2
GS72182	60 x 50 x 0,8	2
GS72183	70 x 55 x 0,8	2

GOLDENSHIP

Bisagra de acero inox
 AISI-316, con separadores
 anti-fricción de nylon.
 Acabado pulido a espejo.

Made in stainless steel
 AISI-316, with anti-
 friction nylon inserts.
 Mirror polished.

Cerniera AISI-316
 in acciaio inox con
 distanziali in nylon
 antifrizione.
 Levigato riflettente.

REF	A (mm)	B (mm)	C (mm)	
GS72190	51	51	102	1
GS72191	63	63	127	1

GOLDENSHIP

GOLDENSHIP

Bisagra de acero inox
 AISI-316, con separadores
 anti-fricción de nylon.
 Acabado pulido a espejo.

Made in stainless steel
 AISI-316, with anti-
 friction nylon inserts.
 Mirror polished.

Cerniera AISI-316
 in acciaio inox con
 distanziali in nylon
 antifrizione.
 Levigato riflettente.

REF	A (mm)	B (mm)	C (mm)	D (mm)	
GS72187	51	51	102	3	1
GS72188	63	63	127	3	1
GS72189	76	76	152	4,8	1

GOLDENSHIP

GOLDENSHIP



TIRADOR • LATCH • CHIUSURA BOCCAPORTI

TIRADOR PESTILLO FLUSH RING LATCH ALZAPAGLILOLO

Fabricada en acero inox AISI 316. Stainless steel AISI-316. In acciaio inox AISI 316.
Hole Ø: 2" Hole Ø: 2" Ø montaggio: 50 mm.

REF	LLAVE KEY CHIAVE	A (mm)	B (mm)	C (mm)	
GS72417		73	60	63	1
GS72418	✓	73	60	63	1

GOLDENSHIP

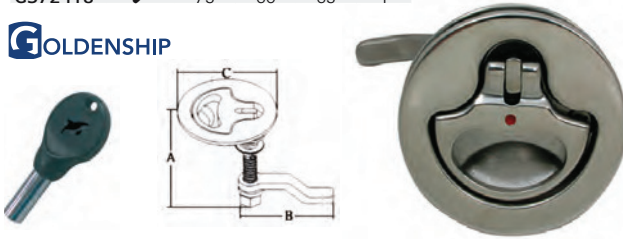

Fabricada en acero inox AISI 316. Stainless steel AISI-316. In acciaio inox AISI 316.
Hole Ø: 2" Hole Ø: 2" Ø montaggio: 50 mm.

REF	LLAVE KEY CHIAVE	(mm)	A (mm)	B (mm)	C (mm)	D (mm)	
GS72415		63 x 63	73	63	63	60	1
GS72416	✓	63 x 63	73	63	63	60	1

GOLDENSHIP

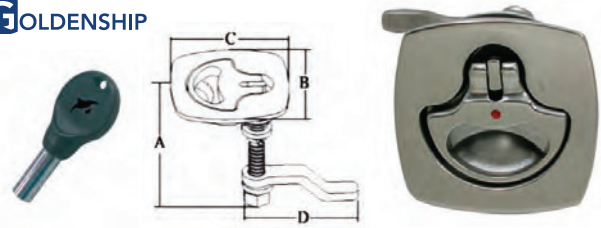

Fabricada en acero inox AISI 316. Stainless steel AISI-316. In acciaio inox AISI 316.
Hole Ø: 2-3/4" Hole Ø: 2-3/4" Ø montaggio: 70 mm.

REF	LLAVE KEY CHIAVE	A (mm)	B (mm)	
GS72419		76-38	79	1
GS72420	✓	76-38	79	1

GOLDENSHIP

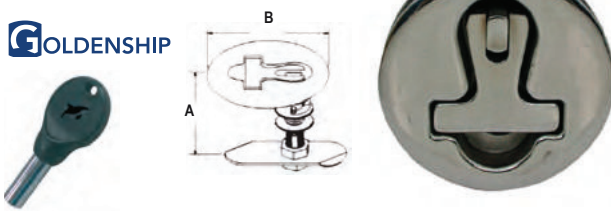

Fabricado en latón cromado. Chrome plated zinc alloy. In ottone cromato.

REF	(mm)	
GS72427	60 x 50	1

GOLDENSHIP



Fabricada en acero inox AISI 316. Stainless steel AISI-316. In acciaio inox AISI 316.

REF	(mm)	
GS72374	57 x 35	1

GOLDENSHIP

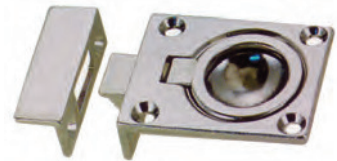

Fabricada en acero inox AISI 316. Stainless steel AISI-316. In acciaio inox AISI 316.
Hole Ø: 2-3/4" Hole Ø: 2-3/4" Ø montaggio: 70 mm.

REF	LLAVE KEY CHIAVE	A (mm)	B (mm)	C (mm)	
GS72421		76-38	63	76	1
GS72422	✓	76-38	63	76	1

GOLDENSHIP

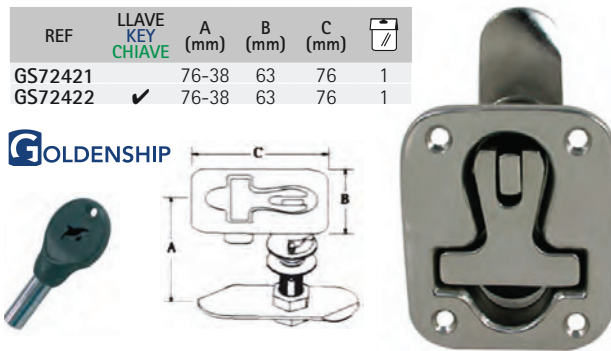

Fabricado en latón cromado y plástico. Chrome plated zinc alloy and plastic.
Montaje empotrado, Ø 51 mm. Door thickness: 1/4 to 1-1/8".
Para puertas de 6 a 28 mm. Hole Ø: 2".
Measures: 2-1/2 x 2-1/2"

In ottone cromato e plastica. Montaggio ad incasso, Ø 51 mm. Per porte da 6 a 28 mm.

REF	LLAVE KEY CHIAVE	(mm)	
GS72364	■	63 x 63	1
GS72365	□	63 x 63	1
GS72366	■	63 x 63	1
GS72367	□	63 x 63	1

PERKO®



Fabricada en acero inox AISI 316. Stainless steel AISI-316. In acciaio inox AISI 316.

REF	LLAVE KEY CHIAVE	A (mm)	B (mm)	C (mm)	
GS72423		90-79	79	96	1
GS72424	✓	90-79	79	96	1

GOLDENSHIP

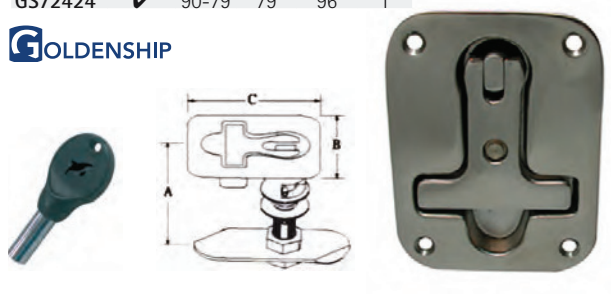

TIRADOR TAMBUCHO HATCH PULL ALZAPAGLILOLO

Fabricada en acero inox AISI 316. Stainless steel AISI-316. In acciaio inox AISI 316.

REF	(mm)	
GS72383	Ø32 x 50	1

GOLDENSHIP



**TIRADOR CON TAPA
FLOOR LATCH
CHIUSURA BOCCAPORTI**

Fabricado en acero inox.
AISI-316
Montaje empotrado.
Cerradura incorporada.

Made in stainless steel
AISI-316.
Flush mount.
With key.

In acciaio inox AISI 316.
Montaggio ad incasso.
Serratura incorporata.

REF	(mm)	
GS72409	75 x 60	1

GOLDENSHIP



Fabricado en acero inox.
AISI-316
Montaje empotrado.

Made in stainless steel.
Flush mount.

In acciaio inox AISI 316.
Montaggio ad incasso

REF	(mm)	
GS72379	110 x 100	1

GOLDENSHIP



Tirador para tapas de
cofres y tambuchos.
Totalmente estanco.
Fabricado en latón
cromado y plástico.
Montaje empotrado, Ø
63 mm.
Para puertas de 4 a 19
mm.

T-handle.
Waterproof.
Chrome plated zinc alloy
and plastic.
Door thickness: 1/8 to
3/4"

Chiusura boccaporti.
Totalmente stagno.
In ottone cromato e
plastica.
Montaggio ad incasso, Ø
63mm.
Per porte da 4 a 19 mm.

REF	LLAVE KEY CHIAVE	(mm)	
GS72412		Ø 76	1
GS72411	✓	Ø 76	1

PERKO®



Fabricada en acero inox
AISI 316.

Stainless steel AISI-316.

In acciaio inox AISI 316

REF	A (mm)	B (mm)	C (mm)	
GS72425	51	13	4,5	1
GS72426	41	13	4,5	1

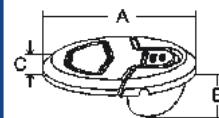

GOLDENSHIP



GS72425



GS72426

Fabricada en acero inox
AISI 316.

Stainless steel AISI-316.

In acciaio inox AISI 316

REF	(mm)	
GS72370	38 x 45	1

GOLDENSHIP



Fabricada en acero inox

Stainless steel .

In acciaio inox

REF	(mm)	
GS72369	89 x 29	

GOLDENSHIP



Fabricado en fundición de
acero inox AISI-316.

Cast stainless steel AISI-
316.

In acciaio inox AISI 316

REF	(mm)	
GS72371	76 x 57	1

GOLDENSHIP



Fabricado en acero inox.
Con muelle de retención.

Made in stainless steel.
Spring loaded.

In acciaio inox. Con molle.

REF	(mm)	
GS72372	55 x 66 x 1	1
GS72375	38 x 44 x 1	1

GOLDENSHIP



Fabricada en acero inox
AISI 316.

Stainless steel AISI-316.

In acciaio inox AISI 316

REF	(mm)	
GS72414	Ø50 x 2,5	1

GOLDENSHIP



REF	(mm)	
GS72373	75 x 58 x 1	1

GOLDENSHIP



CIERRE • LOCK • SERRATURA

CIERRE SEGURIDAD HASP SERRATURA DI SICUREZZA

Fabricada en acero inox AISI 316. Stainless steel AISI-316. In acciaio inox AISI 316

REF	(mm)	
GS72352	75 x 25	1

Giratorio
Swivel
Rotante



Fabricada en acero inox Stamped stainless steel. In acciaio inox

REF	(mm)	
GS72350	67 x 25 x 1,5	1
GS72351	67 x 25 x 1,5	1

Fijo
Fixed
Fisso
Giratorio
Swivel
Rotante



CIERRE PUERTA DOOR BUTTON SERRATURA PORTA

Fabricado en latón cromado y plástico negro. Chrome plated zinc with plastic knob. In ottone cromato e plastica negra.

REF	(mm)	
GS72362	Ø45	1



CIERRE CON LLAVE LOCKING HASP SERRATURA CON CHIAVE

Fabricada en acero inox Stainless steel. In acciaio inox

REF	(mm)	
GS72353	79 x 30	1



Fabricado en latón cromado y acero inox. Tapa de plástico. Ø montaje: 20 mm. Made of chrome brass and stainless steel. With watertight cap. Hole Ø: 20 mm. Realizzato in ottone cromato e acciaio inox. Coperchio di plastica. Ø montaggio: 20 mm.

REF	(mm)	
GS72381	16	1
GS72382	30	1



VENTICIERRE ELBOW CATCH CHIUSURA A CADUTA

Fabricado en latón pulido y aro de madera de teka. Made of polished brass with teak ring. In ottone pulito e boccia in teak.

REF	(mm)	
GS72398	Ø 39	1



CIERRE A PRESION HATCH FASTENER SERRATURA A PRESIONE

Fabricado en goma termo-elástica y bases de acero inox. Antivibration latch made of thermo elastic rubber with mounting plates in stainless steel. In gomma termoplastica e base in acciaio inox.

REF	(mm)	
GS72428	96 x 29	1

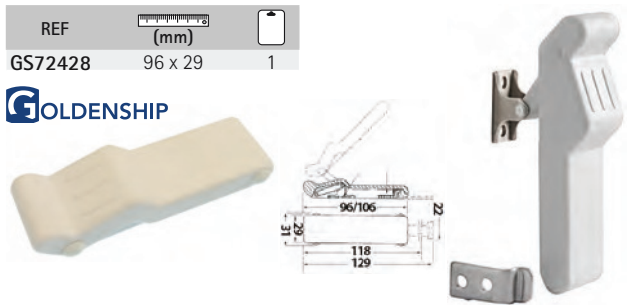

Fabricada en acero inox AISI 316. Stainless steel AISI-316. In acciaio inox

REF	(mm)	
GS72361	115 x 50	1
GS72396	100 x 30	1
GS72397	92 x 30	1



CIERRE CON MUELLE SPRING LOADED DOOR LATCH SERRATURA CON MOLLA

Fabricado en acero inox AISI 316 con pasador de nylon. Stainless steel AISI-316 and nylon slide. In acciaio inox AISI 316 con passante in nylon. Si può cambiare la posizione di chiusura semplicemente smontando il pomello e girando il passante. The slide ramp can be easily changed by removing the latch knob and reversing the slide.

REF	A (mm)	B (mm)	C (mm)	D (mm)	
GS72432	72	27	19	30	1

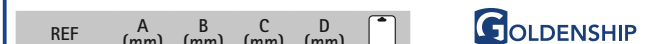

**CIERRE GUANTERA
LOCK & LATCH
SERRATURA E CHIUSURA**

Fabricada en plástico resistente a los rayos UV. Color negro. Con llave.

Black plastic UV resistant. With key

In plastica resistente ai raggi UV. Colore nero. Con chiave.

REF	
GS72408	1

PERKO®



**CIERRE PESTILLO
FLUSH LOCK
SERRATURA**

Con llave. Fabricado en zinc cromado. Montaje empotrado, Ø 41 mm. Para puertas de 13 a 19 mm.

Chrome plated zinc alloy. Door thickness: 1/2 to 3/4" Hole Ø: 1-5/8"

Con chiave. In zinco cromato. Montaggio ad incasso, Ø 41 mm. Per porte da 13 a 19 mm.

REF		(mm)
GS72355	1	51 x 57

PERKO®



Cierre a presión, con botón de latón, para guanteras, cajones, puertas, etc. Mecanismo de plástico blanco. Para puertas de 16 mm.

Latch in white plastic with push button in brass. For thickness of 16 mm.

Chiusura a pressione, con bottone in ottone, per porte, casse etc. Meccanismo in plastica bianca. Per porte da 16mm.

REF	
GS72440	1
GS72441	1

GOLDENSHIP



Cierre interior. Fabricada en latón cromado. Montaje superpuesto.

Chrome plated zinc. Locked by turn button from inside.

Chiusura interna. In ottone cromato. Montaggio sovrapposto

REF	BISEL BEVEL FRONTALINO	CAJA CASE CASSA	
GS72356	Standard	54 x 44	1
GS72357	Reverso Opposto	54 x 44	1

PERKO®



Fabricada en zamack cromado. Apertura por pulsador.

Latch in chromed zamack with push button opening.

In Zamak cromato. Apertura con pulsante.

REF	
GS72407	1

GOLDENSHIP



Cierre interior. Fabricada en acero inox. Montaje superpuesto.

Made in stainless steel. Locked by turn button from inside.

Chiusura interna. In acciaio inox. Montaggio sovrapposto

REF	BISEL BEVEL FRONTALINO	CAJA CASE CASSA	PLACA ESCUTCHEON PIASTRA	
GS72358	Standard	54 x 44	111 x 32	1

GOLDENSHIP



**CERRADURA
RIM LOCK SET
SERRATURA**

Con llave. Cierre interior. Fabricada en latón cromado. Montaje superpuesto.

Chrome plated zinc. Locked by turn button from inside and outside key.

Con chiave. Chiusura interna. In ottone cromato. Montaggio sovrapposto.

REF	BISEL BEVEL FRONTALINO	CAJA CASE CASSA	PLACA ESCUTCHEON PIASTRA	
GS72400	Standard	98 x 50	111 x 32	1
GS72401	Reverso Reverso	98 x 50	111 x 32	1

PERKO®

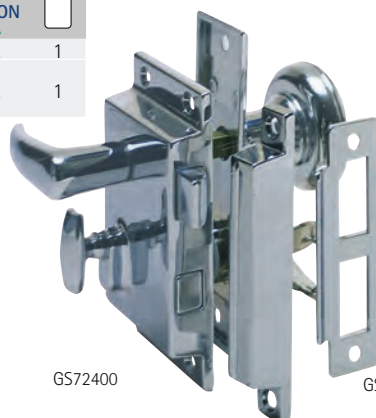

GS72400

GS72401



CIERRE TAMBUCHO
DECK HOUSE LOCK
SERRATURA

Con llave exterior y pomo interno.
Fabricado en latón cromado.
Para puertas de hasta 20 mm.

Chrome plated zinc.
Door thickness: up to 3/4"

Con chiave esterna e pomello interno.
In ottone cromato.
Per porte da 20 mm in su.

REF	(mm)	
GS72410	62 x 53	1

GOLDENSHIP



CIERRE PASADOR
CUPBOARD BOLT
SERRATURA

Fabricado en latón cromado.

Chrome plated zinc alloy. In ottone cromato.

REF	(mm)	
GS72363	54 x 38	1

PERKO®

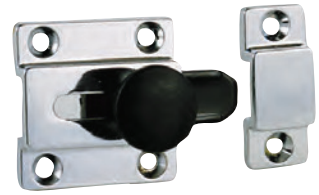

Fabricada en acero inox AISI 316.

Stainless steel AISI-316. In acciaio inox.

REF	(mm)	
GS72404	63 x 30	1
GS72405	89 x 39	1
GS72406	115 x 39	1
GS72429	76 x 30	1

GOLDENSHIP



CANDADO MARINO • MARINE PADLOCK • LUCCHETTO MARINO

CANDADO MARINO
MARINE PADLOCK
LUCCHETTO MARINO

Candado marino con protección de plástico.

Waterproof padlock. With plastic cover.

Lucchetto marino con protezione in plastica.

REF	(mm)	
GS76038	45	1

GOLDENSHIP



Juego de 3 candados marinos con la misma llave.

Set of 3 marine padlocks with the same key.

Set di 3 lucchetti con la stessa chiave.

REF	A (mm)	B (mm)	C (mm)	D (mm)	
GS76080	30	22	13	5	3
GS76081	40	33	14	6	3
GS76082	50	40	16	8	3

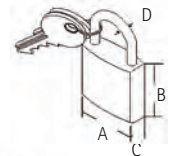

GOLDENSHIP



Candado marino con cuerpo de latón y aro de acero inox.

Marine padlock made of brass with stainless steel shackle

Lucchetto marino con corpo in ottone e anello in acciaio inox.

REF	A (mm)	B (mm)	C (mm)	D (mm)	
GS76039	30	22	13	5	1
GS76040	40	33	14	6	1
GS76041	50	40	16	8	1

GOLDENSHIP

