

MARINE POWER

The Force Behind the Fun[®]



MARINE POWER su potpuno novi motori sa CE certifikatom

MARINE POWER motori su dostupni na dva nacina:

* kao KOMPLETNI MOTORI: spremni da u potpunosti zamjene postojeći motor, također i kao zamjene za EFI motore

* kao BLOK MOTORA: kao zamjena za postojeći blok uz ugradnju novih ili postojećih dijelova za marinizaciju

MARINE POWER kompletni motori imaju dvije godine garancije, a BLOK MOTORA ima jednu godinu garancije.

MARINE POWER engines are brand new blocks with CE certificates

These marine engines are supplied in two ways:

* *COMPLETE ENGINE: Ready to substitute other brands, including EFI engines (injection)*

* *BLOCK ENGINES: To be converted to marine engines with the parts we substitute*

*Complete MARINE POWER engines come with **two year** warranty and block engines come with **one year** warranty from the date of installation.*

Model motora - Engine model: 181 Standard (3.0L)

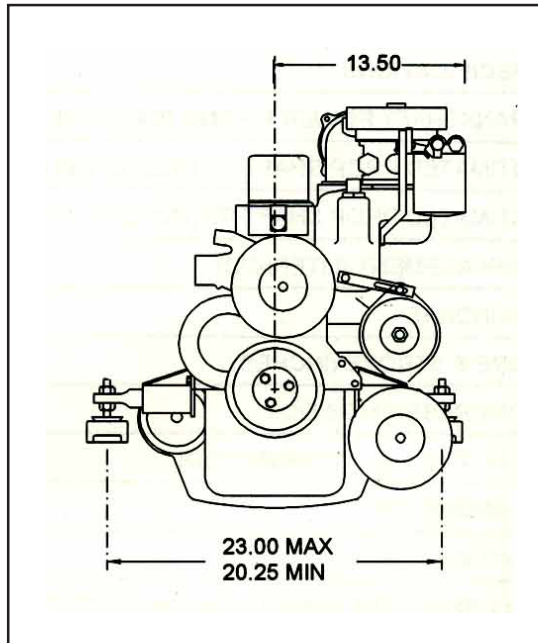

Front view **MPE181S**

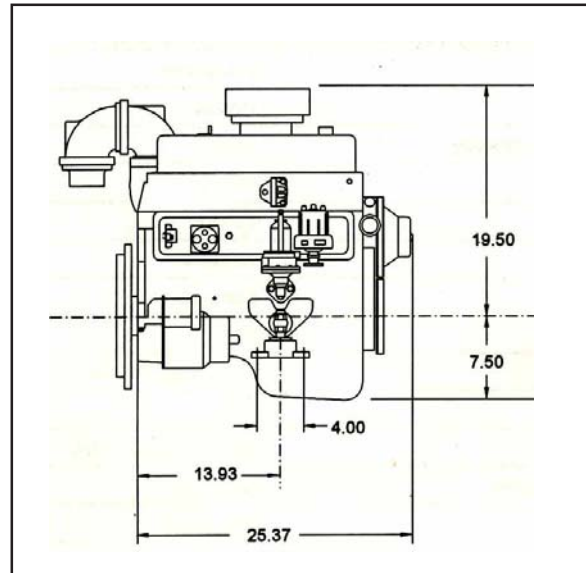

Side view **MPE181S**

SPECIFIKACIJE

Crankshaft power rating
Prop shaft rating
Cylinders
Compression ratio
Carburetor
Ignition
Full throttle operation
Total weight

STANDARD

140/104
130/97
4 in line
9.25:1
2 BBL
Delco electronic
4300-4600(RPM)
185 Kg

OPCIJE

Complete engine options MPE181S

Fresh water cooling system
OMC exhaust package
Alarm system
12 3/4" flywheel
Instrument panel
TBI Throttle Body Injection

STANDARDNA OPREMA BLOKA MOTORA MPB181S STANDARD EQUIPMENT

14" flywheel
Cylinder heads
All internal components
Oil pan
Water pump

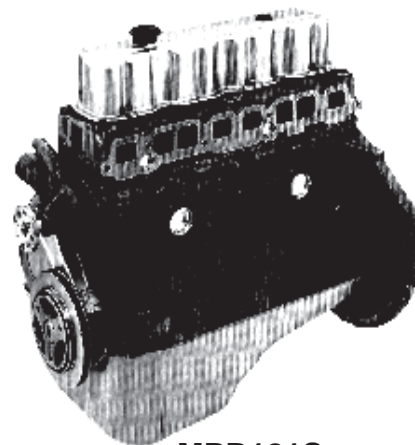

MPB181S

Model motora - Engine model: 4.3 vortec (4.3L) - 262 CID

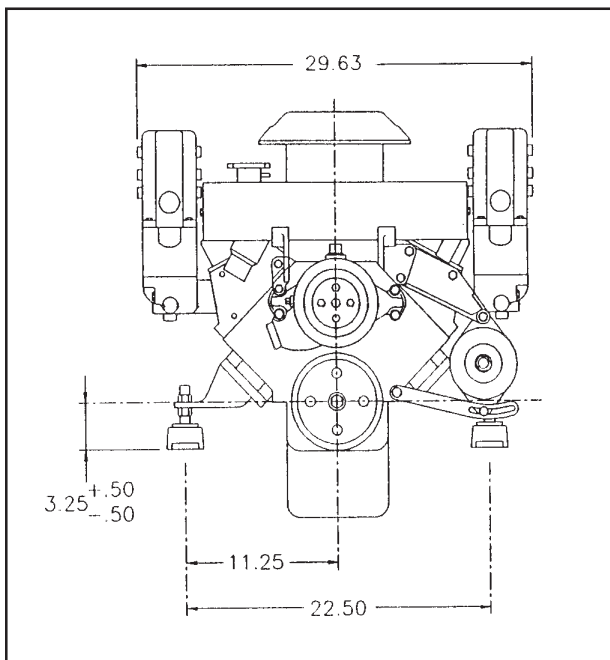

Front view **MPE4.3V-MR2**

SPECIFIKACIJE

Crankshaft power rating
Prop shaft rating
Cylinders
Compression ratio
Carburetor
Ignition
Full throttle operation
Total weight

OPCIJE

Complete engine options MPE4.3V-MR2

Fresh water cooling system
OMC exhaust package
Alarm system
12 3/4" flywheel
Instrument panel
TBI Throttle Body Injection

STANDARDNA OPREMA BLOKA MOTORA

STANDARD EQUIPMENT

14" flywheel
Cylinder heads
All internal components
Oil pan
Water pump

MPB4.3V

BLOK MOTORA SA ELEKTRICNOM PUMPOM I
BALANS STANGOM

Replaces engines with electric fuel pump and balanced shaft

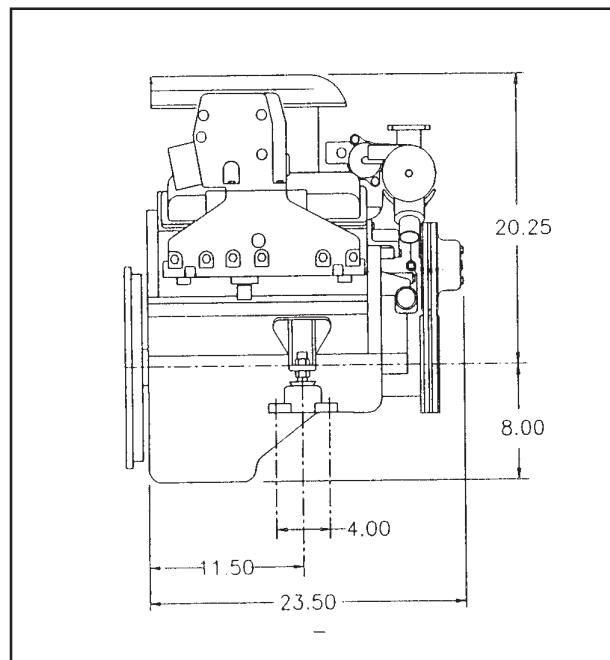

Side view **MPE4.3V-MR2**

STANDARD

225/167
209/156
V6
9.4:1
4 BBL
Delco electronic
4300-4600(RPM)
241 Kg

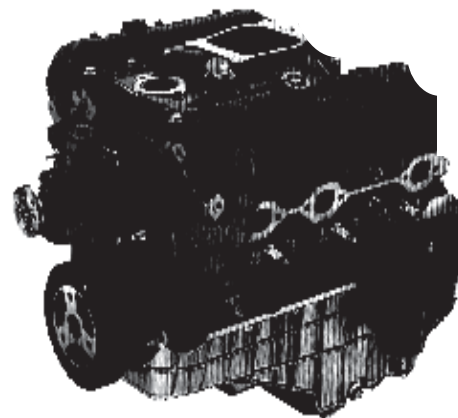

Model motora - Engine model: 5.7 vortec - 350 CID

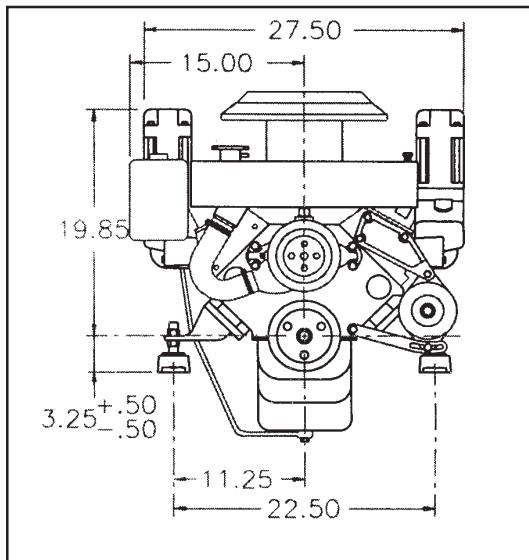

Front view

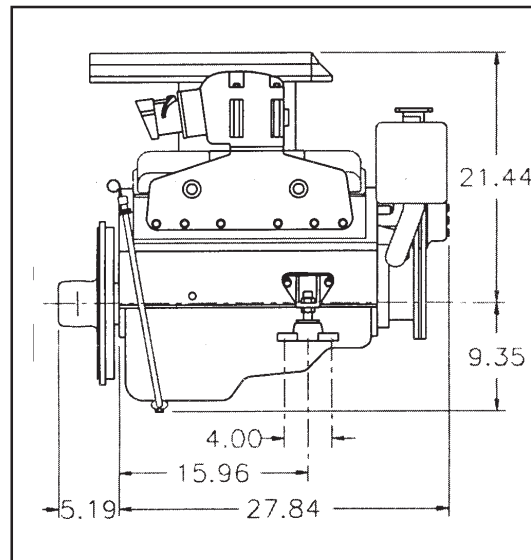

Side view

MOTORI NAPRAVLJENI KAO ZAMIJENA MERCUISER I VOLVO *Engines ready to substitute Mercruiser and Volvo*

MPE5.7V-MR2

MOTOR SA RASPLINJACEM KOJI MIJENJA NOVIJE MODELE MERCUISERA OD 1996

Carburated engine ready to substitute Mercruiser engines since 1986

MPE5.7V-MR2MPI

EFI MOTOR KOJI MIJENJA NOVIJE MODELE OD 1996

EFI engine ready to substitute Mercruiser engines since 1986

MPE5.7V-VR1

MOTOR SA RASPLINJACEM KOJI MIJENJA VOLVO MOTORE SA 270, 275, 280 I 290 NOGAMA.

Carburated engine ready to substitute Volvo engines with Volvo drives

MPE5.7V-VR1MPI

EFIMOTOR KOJI MIJENJA VOLVO MOTORE SA 270, 275, 280 I 290 NOGAMA.

EFI engine ready to substitute Volvo engines with Volvo drives

MPE5.7V-VR2

MOTOR SA RASPLINJACEM KOJI MIJENJA VOLVO MOTORE SA SX NOGAMA

Carburated engine ready to substitute Volvo engines with SX drives

MPE5.7V-VR2MPI

EFI MOTOR KOJI MIJENJA VOLVO MOTORE SA SX NOGAMA

EFI engine ready to substitute Volvo engines with SX drives

Model motora - Engine model: 5.7 vortec - 350 CID

SPECIFIKACIJE

	<i>Carburated</i>	<i>EFI</i>
<i>Crankshaft power rating</i>	325	345
<i>Prop shaft rating</i>	292	302
<i>Cylinders</i>	8	8
<i>Compression ratio</i>	9.4:1	9.4:1
<i>Carburetor</i>	4BBL Holley	-
<i>Injection</i>	-	M.P.I.
<i>Ignition</i>	Delco Electronic	Delco Electronic
<i>Full throttle operation</i>	4600-5000	4600-5000
<i>Total weight</i>	325 kg	325 kg

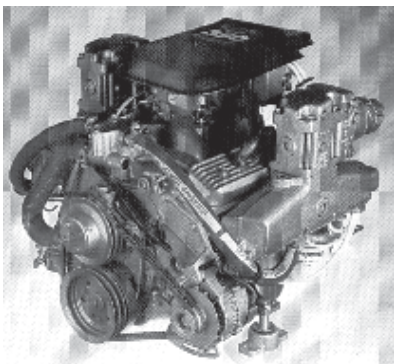

OPCIJE

Enpac Optional equipment

- Fresh water cooling system*
- Instrument panel*
- Alarm system*

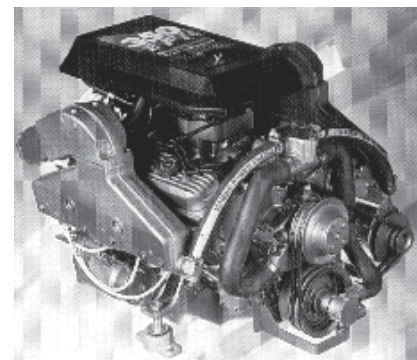

MPB350S

MIJENJA BLOKOVE SA MEHANIČKOM PUMPOM BENZINA
Replaces engines with mechanical fuel pump

MPB5.7V

MIJENJA BLOKOVE SA ELEKTRIČNOM PUMPOM BENZINA
Replaces engines with electric fuel pump

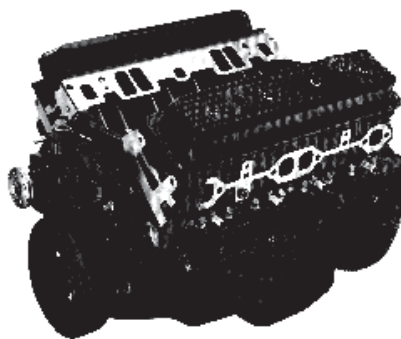

STANDARDNA OPREMA BAZE MOTORA *Standard base equipment*

- Flywheel*
- Cylinder heads*
- Oil pan*
- Water pump*
- Internal components*

Model motora - Engine model: 454 Standard, 7.4 Vortec

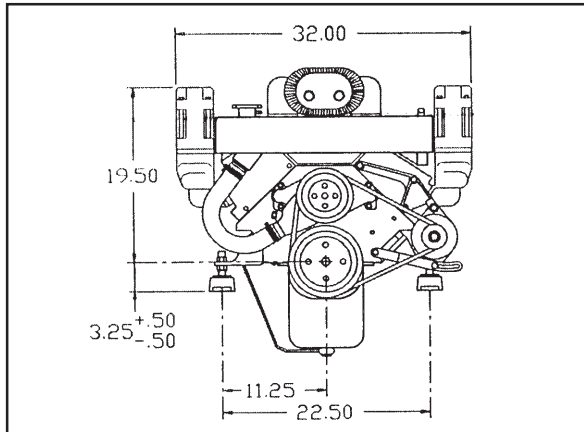

Vista frontal - Front view

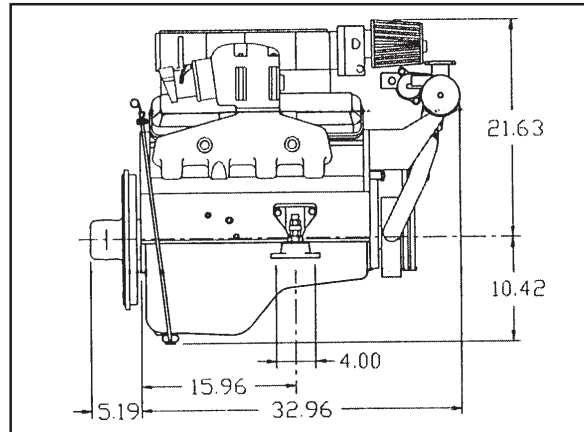

Vista lateral - Side view

MPE454S-MR2

MOTOR SA RASPLINJACEM NAPRAVLJEN KAO ZAMJENA ZA MERCUISER MODELE OD 1996
Carbureted engine ready to substitute Mercruiser engines since 1986

MPE7.4V-MR2

EFI MOTOR NAPRAVLJEN KAO ZAMJENA ZA MERCUISER MODELE OD 1996
EFI engine ready to substitute Mercruiser engines since 1986

SPECIFIKACIJE

Crankshaft power rating
Prop shaft rating
Cylinders
Compression ratio
Carburetor
Injection
Ignition
Full throttle operation
Total weight

454S

330
307
V8
8.6:1
4 BBL Holley
-
Delco electronic
4300-4600
400 kg

7.4V

340
313
V8
9.0:1
-
MPI
Delco electronic
4200-4600
400 kg

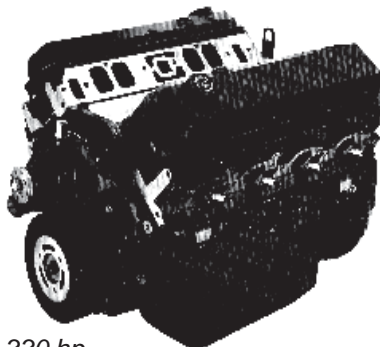

MPB454S

Block engine 7.4L - 330 hp

STANDARDNA OPREMA BAZE MOTORA Standard base equipment

Flywheel
Cylinder heads
Oil pan
Water pump
Internal components

OPCIJE - Enpac Optional equipment

Front mounted Fresh water cooling system
Instrument panel
Alarm system

Model motora - Engine models: 454 Premium, EFI

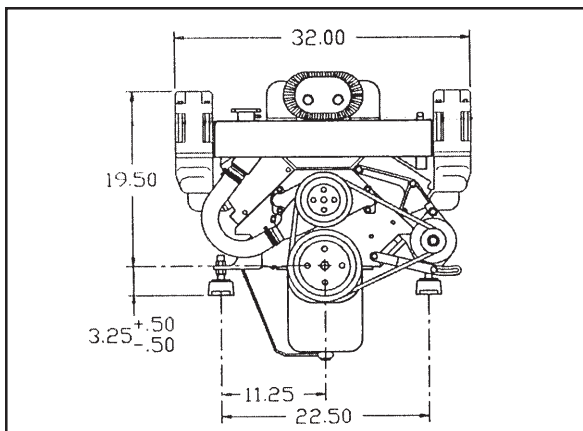

Front view

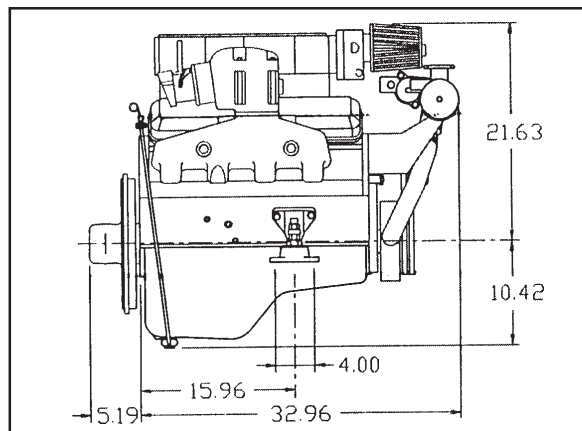

Side view

MPE454P-MR2

MOTOR SARASPLINACEM NAPRAVLJEN KAO ZAMJENA ZA MERCUISER MODELE OD 1986

Carburated engine ready to substitute Mercruiser engines since 1986

MPE454P-MR2MPI

EFI MOTOR NAPRAVLJEN KAO ZAMJENA ZA MERCUISER MODELE OD 1986

EFI engine ready to substitute Mercruiser engines since 1986

SPECIFIKACIJE

Crankshaft power rating

Prop shaft rating

Cylinders

Compression ratio

Carburetor

Injection

Ignition

Full throttle operation

Total weight

454P

380

353

V8

8.6:1

4 BBL Holley

-

Delco electronic

4800-5200

400 kg

454PMPI

420

385

V8

9.4:1

-

MPI - MPI

Delco electronic

4800-5200

400 kg

OPCIJE

Enpac Optional equipment

Front mounted Fresh water cooling system

Instrument panel

Alarm system

STANARDNE OPCIJE BAZE

Standard base equipment

Flywheel

Cylinder heads

Oil pan

Water pump

Internal components

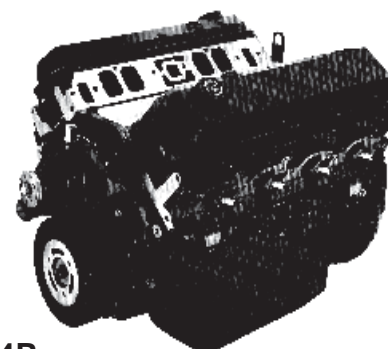

MPB454P

Block engine 454 magnum - 380 hp

Modeli motora - Engine models: 502 Premium & 502 Premium MPI

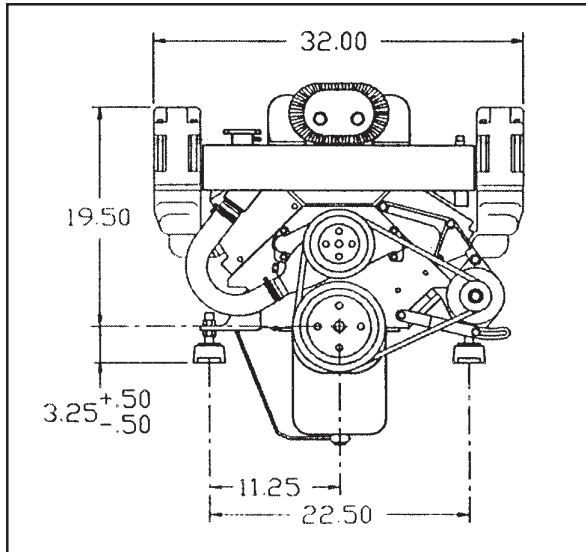

Front view

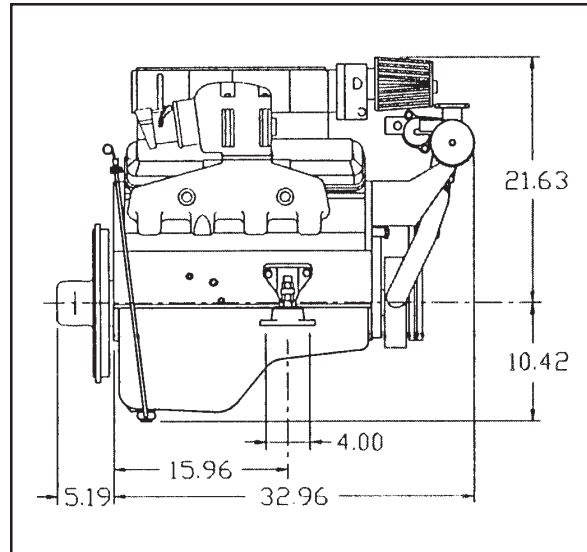

Side view

MPE502P-MR2

MOTOR SA RASPLINACEM NAPRAVLJENI KAO ZAMJENA ZA MERCUISER MODELE OD 1986

Carburated engine ready to substitute Mercruiser engines since 1986

MPE502P-MR2MPI

EFI MOTOR NAPRAVLJEN KAO ZAMJENA ZA MERCUISER MODELE OD 1986

EFI engine ready to substitute Mercruiser engines since 1986

SPECIFIKACIJE

Crankshaft power rating

502P-MR2

415

502P-MR2MPI

450

Prop shaft rating

372

420

Cylinders

V8

V8

Compression ratio

8.75:1

8.75:1

Carburetor

4 BBL Holley

-

Injection

-

MPI

Ignition

Delco electronic

Delco electronic

Full throttle operation

4300-4800

4300-4800

Total weight

400 kg

400 kg

OPCIJE - Enpac Optional equipment

Front mounted Fresh water cooling system

Instrument panel

Alarm system

STANDARDNA OPREMA BAZE

Standard base equipment

Flywheel

Cylinder heads

Oil pan

Water pump

Internal components

MPB502P

Block engine

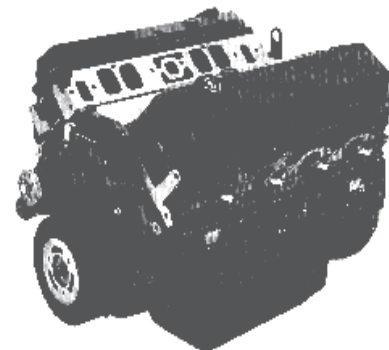

Modeli motora - Engine models: E8.1V-MR2, E8.1HP-MR2

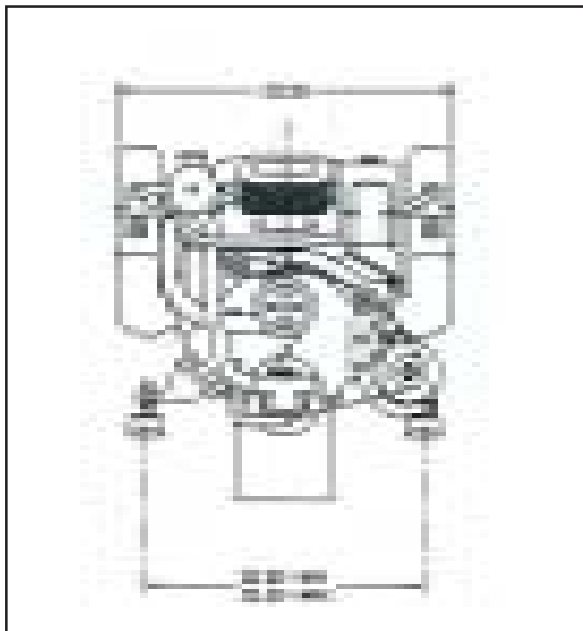

Front view

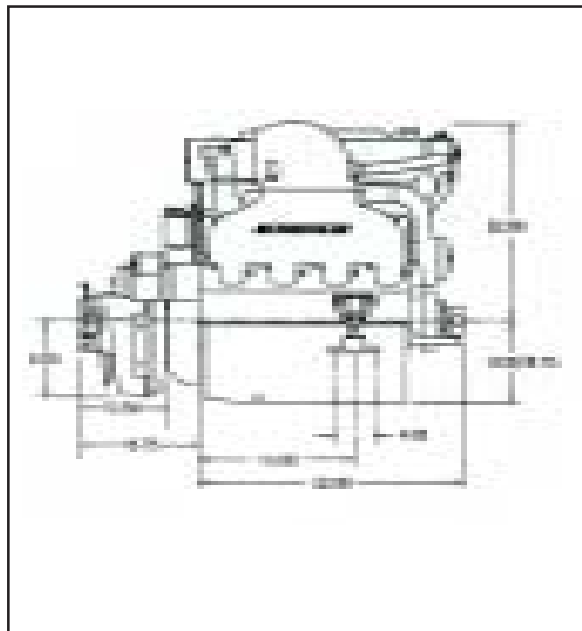

Side view

MPE8.1V-MR2MPI

EFI MOTOR NAPRAVLJEN KAO ZAMJENAZA MERCUISER MODELE OD 1986

EFI engine ready to substitute Mercruiser engines since 1986

MPE8.1HP-MR2MPI

EFI MOTOR NAPRAVLJEN KAO ZAMJENAZA MERCUISER MODELE OD 1986

EFI engine ready to substitute Mercruiser engines since 1986

SPECIFIKACIJE

	8.1V-MR2MPI	8.1HP-MR2MPI
<i>Crankshaft power rating</i>	375	420
<i>Prop shaft rating</i>	365	410
<i>Cylinders</i>	V8	V8
<i>Compression ratio</i>	9.1:1	9.1:1
<i>Injection</i>	MPI	MPI
<i>Ignition</i>	Delco electronic	Delco electronic
<i>Full throttle operation</i>	4600	5000
<i>Total weight</i>	2200 kg	2200 kg

OPCIJE - Enpac Optional equipment

Fresh water cooling system

Instrument panel

Alarm system

Power Steering